

Edging

© 2014 Jennifer Williams

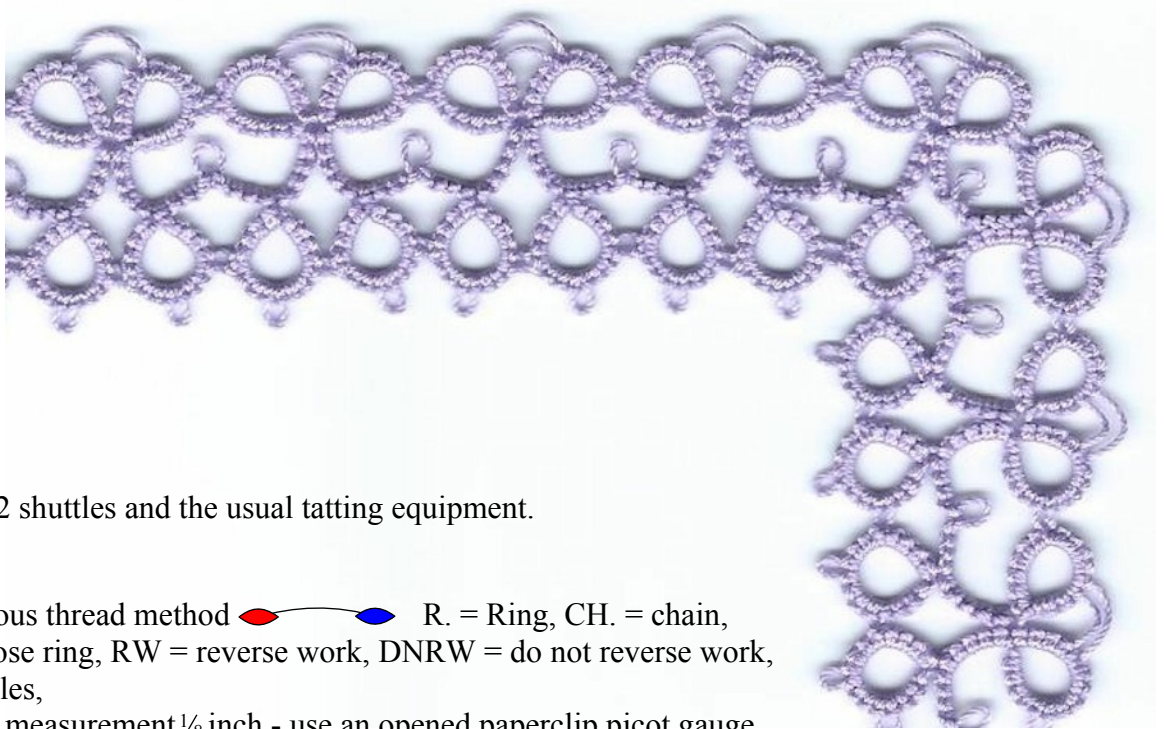

Requirements

Size 20 thread, 2 shuttles and the usual tatting equipment.

Abbreviations:

CTM = continuous thread method  R. = Ring, CH. = chain,
 += join, cl = close ring, RW = reverse work, DNRW = do not reverse work,
 SS = swap shuttles,
 p = picot- open measurement 1/8 inch - use an opened paperclip picot gauge
 mp = medium picot - open measurement 1/4 inch = use a cocktail stick picot gauge
 Lp = large picot - open measurement 5/8 inch - use a coffee stirrer picot gauge
 Dp = downward picot worked 3 second half stitches, mp, 3 first half stitches

Fill 2 shuttles winding them CTM.

- | | | |
|------|-----|---|
| SH.1 | R.A | 6, p, 6, Lp, 4, cl (Fig 1) |
| | R.B | 4, + to Lp on previous ring, 6, p, 6, cl, (Fig 2), RW |
| | CH. | 5, DNRW, SS, (Fig 3) |
| SH.2 | R.C | 4, p, 4, p, 4, p, 4, cl, DNRW, SS |
| SH.1 | CH. | 3, Dp, 3, DNRW, SS |
| SH.2 | R,D | 4, + to previous ring, 4, p, 4, p, 4, cl, DNRW, SS |
| SH.1 | CH. | 5, tension the whole of the chain and 'encourage' the downward picot to drop down below the core thread. (Fig 3) RW |

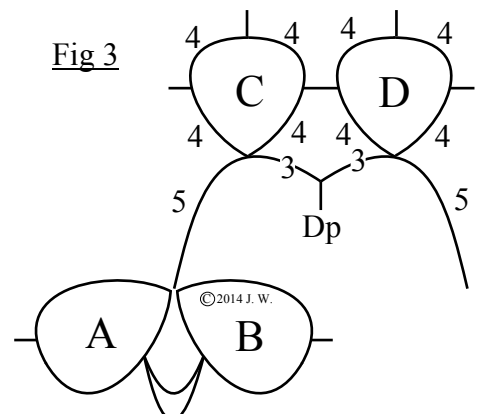
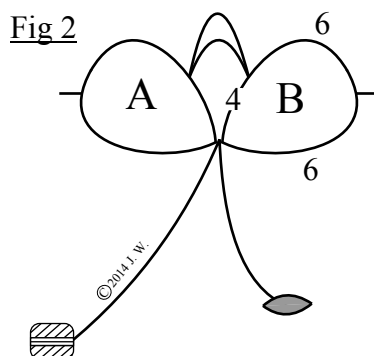
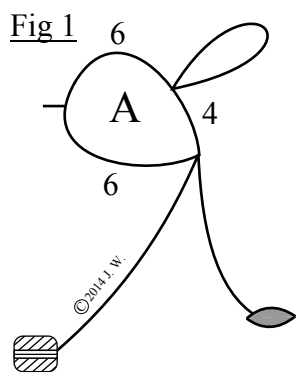

- *SH.1 R.E 6, + to ring 'B', 6, Lp, 4, cl (Fig 4)
- R.F 4, + to Lp on previous ring, 6, p, 6, cl, RW
- CH. 5, DNRW, SS
- SH.2 R.G 4, + to ring 'D', 4, p, 4, p, 4, cl, DNRW, SS
- SH.1 CH. 3, Dp, 3, DNRW, SS
- SH.2 R,H 4, + to previous ring, 4, p, 4, p, 4, cl, DNRW, SS
- SH.1 CH. 5, tension the whole of the chain and 'encourage' the downward picot to drop down below the core thread. RW**

Repeat from * to ** for the length required

Fig 4

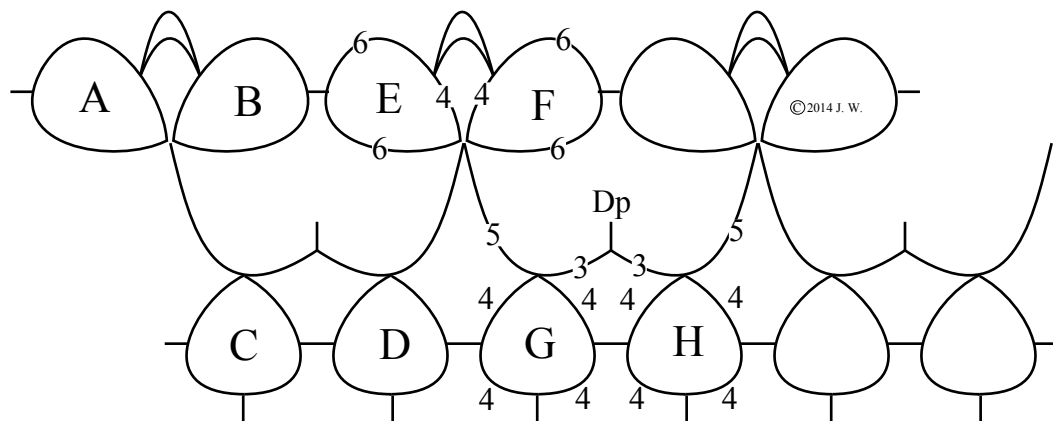

The corner

Fig 5

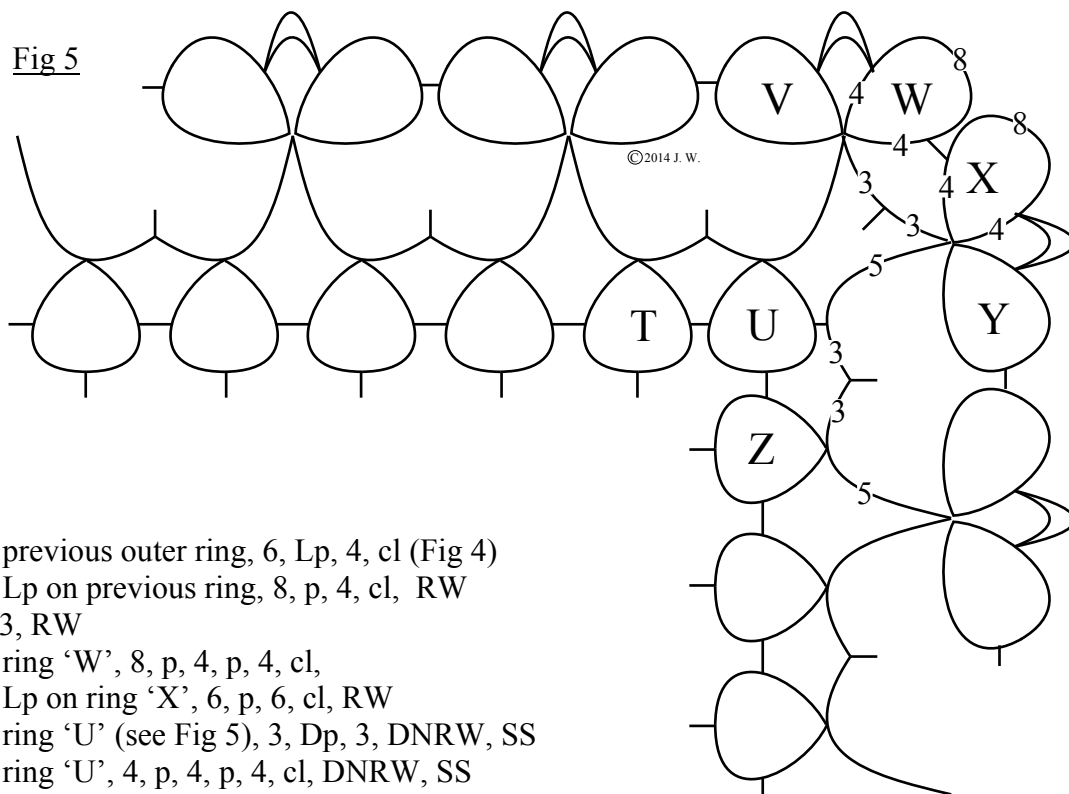

- SH.1 R.V 6, + to previous outer ring, 6, Lp, 4, cl (Fig 4)
- R.W 4, + to Lp on previous ring, 8, p, 4, cl, RW
- CH. 3, Dp, 3, RW
- R.X 4, + to ring 'W', 8, p, 4, p, 4, cl,
- R.Y 4, + to Lp on ring 'X', 6, p, 6, cl, RW
- CH. 5, + to ring 'U' (see Fig 5), 3, Dp, 3, DNRW, SS
- SH.2 R,Z 4, + to ring 'U', 4, p, 4, p, 4, cl, DNRW, SS
- SH.1 CH. 5, tension the whole of the chain and 'encourage' the downward picot to drop down below the core thread. RW

Repeat from * to ** for the length required.

Continue working round the hanky remembering to join the last outer ring to ring 'A' and the last inner ring to ring 'C'.

Cut and tie to the base of rings 'A' and 'B' then sew in the ends to hide them.