

Star

© 2012 Jennifer Williams

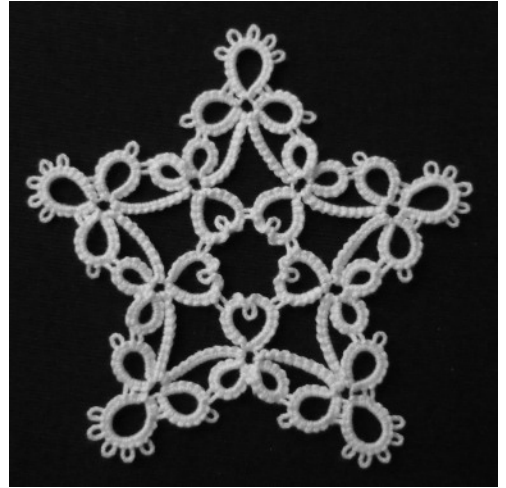

Requirements:

Size 20 thread, 2 shuttles and the usual tatting equipment

Abbreviations:

CTM = continuous thread method



SH. = Shuttle, R. = Ring, p = picot, cl = close ring, + = join,

RW = reverse work, CH. = Chain, SS = swap shuttles,

DNRW = do not reverse work.

Dp = dropped/downward picot made by working 3 second half stitches, leave a space in the thread round your hand for the picot, then work 3 first half stitches.

Wind two shuttles CTM with approximately 5 metres on shuttle 1 and approximately 4 metres on shuttle 2

- | | | |
|------|------|---|
| SH.1 | R.A | 6, p, 2, p, 6, p, 2, cl, |
| | R.B | 2, + to ring 'A', 4, (p, 2) x 4, p, 4, p, 2, cl |
| | R.C | 2, + to ring 'B', 6, p, 2, p, 6, cl, RW |
| | CH. | 10, RW |
| | R.D | 6, + to last picot worked on ring 'C',
5, p, 1, cl |
| | R.E | 1, + to ring 'D', 5, p, 6, cl, RW, SS |
| SH.2 | R.F | 6, p, 2, Dp, 2, p, 6, cl, DNRW, SS |
| SH.1 | CH. | 10, RW |
| | *R.G | 6, + to ring 'E', 2, p, 6, p, 2, cl |
| | R.H | 2, + to ring 'G', 4, (p, 2) x 4, p, 4,
p, 2, cl |
| | R.I | 2, + To ring 'H', 6, p, 2, p, 6, cl, RW |
| | CH. | 10, RW |
| | R.J | 6, + to last picot worked on ring 'I'. 5, p, 1, cl |
| | R.K | 1, + to ring 'J', 5, p, 6, cl, RW, SS |
| SH.2 | R.L | 6, + to ring 'F', 2, Dp, 2, p, 6, cl, DNRW, SS |
| SH.1 | CH. | 10, RW |

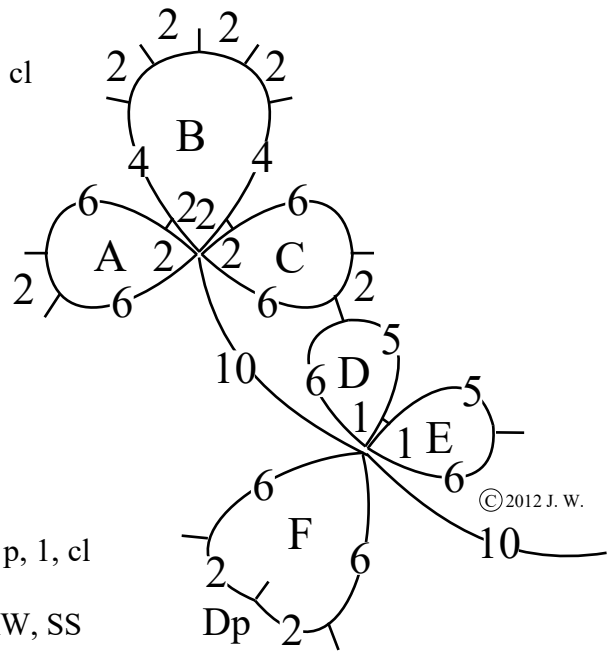

Repeat from * twice more then continue.....

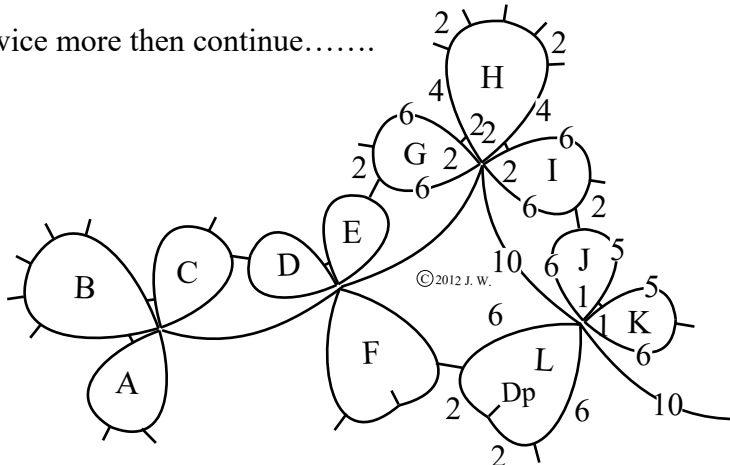

- SH.1 R.U 6, + to ring 'S', 2, p, 6, p, 2, cl
 R.V 2, + to ring 'U', 4, (p, 2) x 4, p, 4, p, 2, cl
 R.W 2, + to ring 'V', 6, p, 2, p, 6, cl, RW
 CH. 10, RW
 R.X 6, + to last worked picot on ring 'W'
 5, p, 1, cl
 R.Y 1, + to ring 'X', 5, + to ring 'A',
 6, cl, RW, SS
- SH.2 R.Z 6, + to ring 'T'. 2, Dp, 2, + to ring 'F',
 6, cl, DNRW, SS
- SH.1 CH. 10

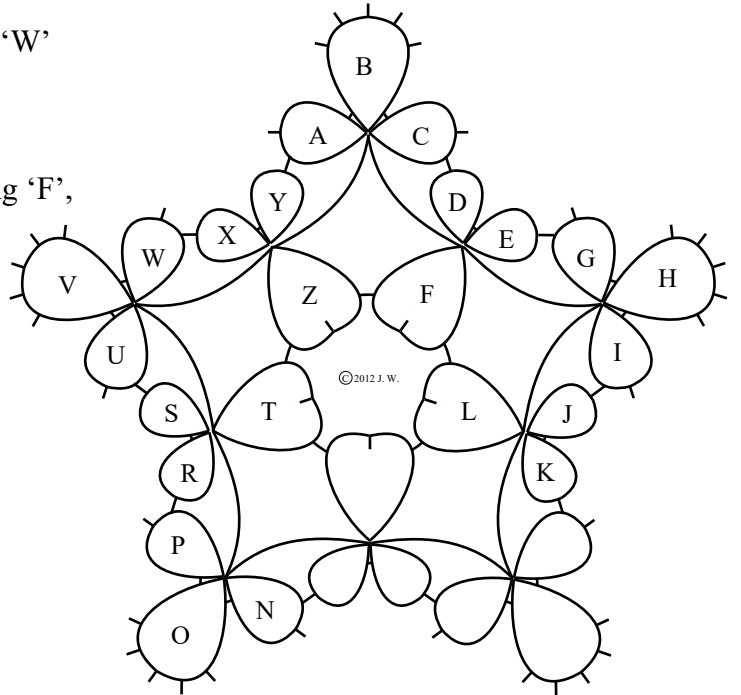

Cut and tie to the base of rings 'A', 'B', and 'C', then secure the ends.
 Block, and stiffen if using as a tree decoration.

Requirements for the beaded version:

Size 20 thread, 60 size 9 or 11 beads, two shuttles, and the usual tating equipment.

String the beads then wind two shuttles CTM with 5 metres and 45 of the beads on shuttle 1 and 4 metres with 15 of the beads on shuttle 2.

- SH.1 R.A 6, p, 2, B, 6, p, 2, cl,
 R.B 2, + to ring 'A', 4, B, 2, B, 2, 3B, 2, B, 2 B, 4, p, 2, cl
 R.C 2, + to ring 'B', 6, p, 2, p, 6, cl, RW
 CH. 10, RW
 R.D 6, + to last picot worked on ring 'C', 5, p, 1, cl
 R.E 1, + to ring 'D', 5, p, 6, cl, RW, SS
- SH.2 R.F 6, p, 2, Dp with 3 beads on the picot, 2, p, 6, cl, DNRW, SS
- SH.1 CH. 10, RW

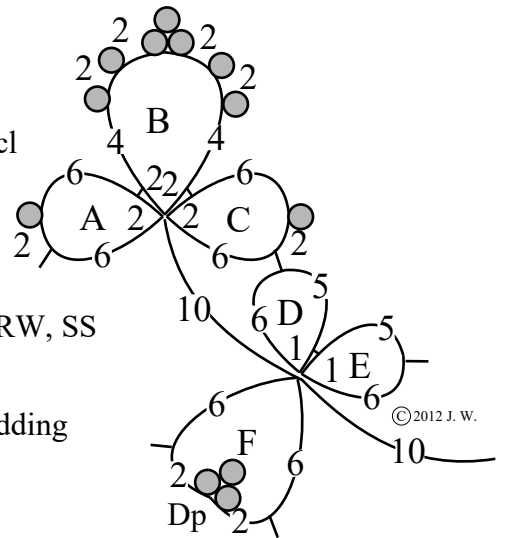

Follow the pattern for the pattern overleaf and at the top of the page adding beads on the rings as above

