

## Snowflake with mock rings

© 2009 Jennifer Williams

### Requirements:

Size 20 thread and your usual tatting equipment.

Wind about 2 metres on your shuttle. Do not cut.

### Row 1

R.A 7, p, 3, p, 7, cl, RW

CH. 7, smp, 7, tension to measure  $\frac{3}{4}$  inch (2 cm), RW

R.B 7, + to ring 'A', 3, p, 7, cl, RW

CH. 7, smp, 7, tension as above, RW

\*R.C 7, + to previous ring, 3, p, 7, cl, RW

CH. 7, smp, 7, tension as above, RW

Repeat from \* twice more remembering to join ring 'E' to ring 'A'.

Work a shuttle join to the base of ring 'A', then without cutting the threads, continue to row 2

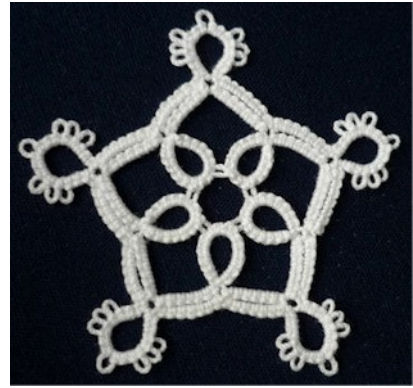

Row 1

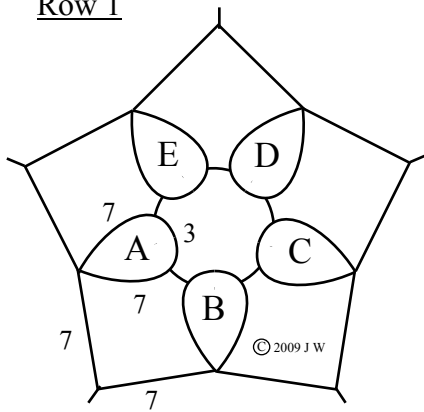

Row 2 added

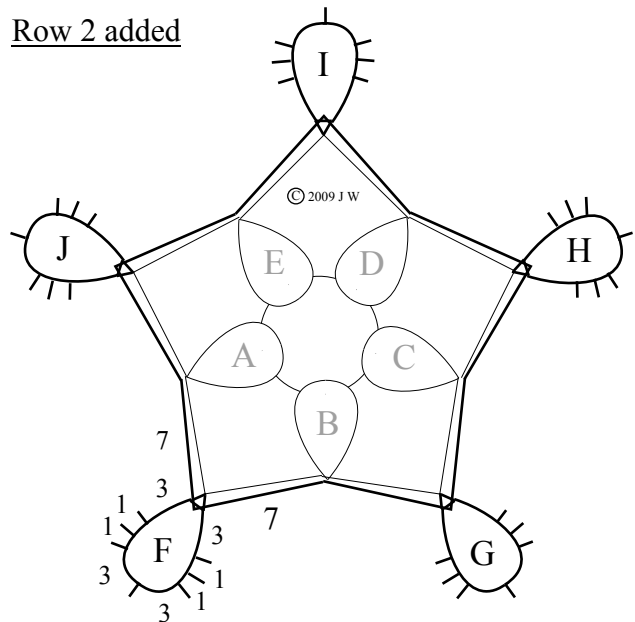

### Row 2 MR. = mock ring

CH. 7, tension to fit snugly over the 1<sup>st</sup> half of the chain of row 1, sj to the picot

MR. chain 3, p, 1, p, 1, p, 3, p, 3, p, 1, p, 1, p, 3, sj to the same picot

CH. 7, tension to fit snugly over the 2<sup>nd</sup> half of the chain of 1<sup>st</sup> row, sj to the small space at the base of the adjacent ring of the 1<sup>st</sup> row.

Repeat from the beginning of the row four times more.

Cut and tie to the start of the row and secure the ends.